

LEFT SIDE COMPARTMENTS				
COMPT	DOORS	OPENING DIMENSIONS	INSIDE DIMENSIONS	VOLUME
L1	ROLL-UP	25.5" w X 57.4" h	31.1" w X 66" h X 27.3" d	29.4 CU. FT. (10" h X 10.5" d UPPER)
L2	ROLL-UP	57.5" w X 28.2" h	61.6" w X 36.8" h X 27.3" d	29.8 CU. FT. (10" h X 10.5" d UPPER)
L3	ROLL-UP	50.5" w X 57.4" h	53.4" w X 66" h X 27.3" d	50.5 CU. FT. (10" h X 10.5" d UPPER)

RIGHT SIDE COMPARTMENTS				
COMPT	DOORS	OPENING DIMENSIONS	INSIDE DIMENSIONS	VOLUME
R1	ROLL-UP	25.5" w X 51.4" h	31.1" w X 60" h X 27.3" d	28.3 CU. FT. (4" h X 10.5" d UPPER)
R2	ROLL-UP	57.5" w X 22.2" h	61.6" w X 30.8" h X 27.3" d	27.6 CU. FT. (4" h X 10.5" d UPPER)
R3	ROLL-UP	50.5" w X 51.4" h	53.4" w X 60" h X 27.3" d	48.6 CU. FT. (4" h X 10.5" d UPPER)

REAR STEP COMPARTMENT				
COMPT	DOORS	OPENING DIMENSIONS	INSIDE DIMENSIONS	VOLUME
A1	ROLL-UP	37.5" w X 32.8" h	40" h X 40" w X 31" d	28.7 CU. FT.
TOTAL:				242.9 CU.FT.

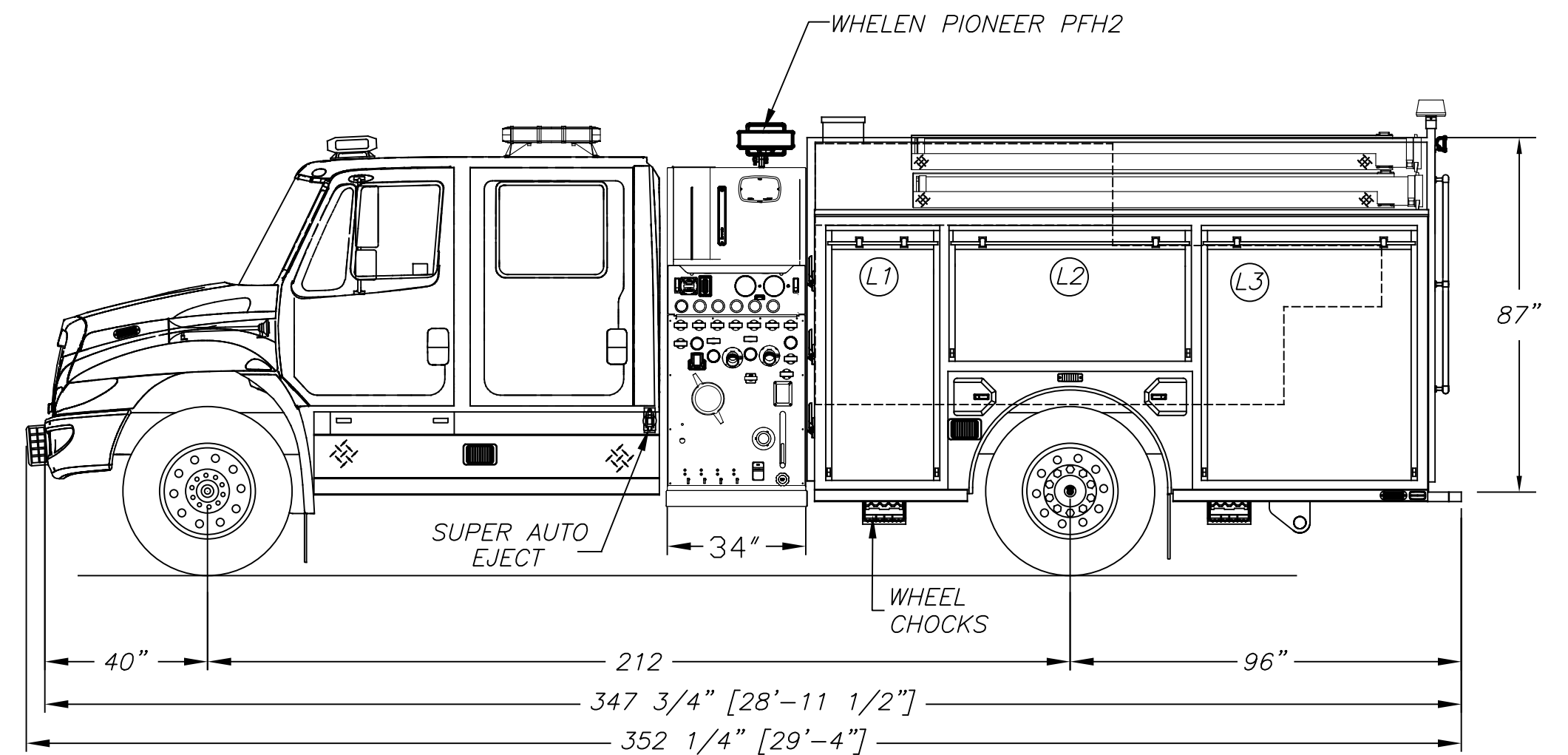
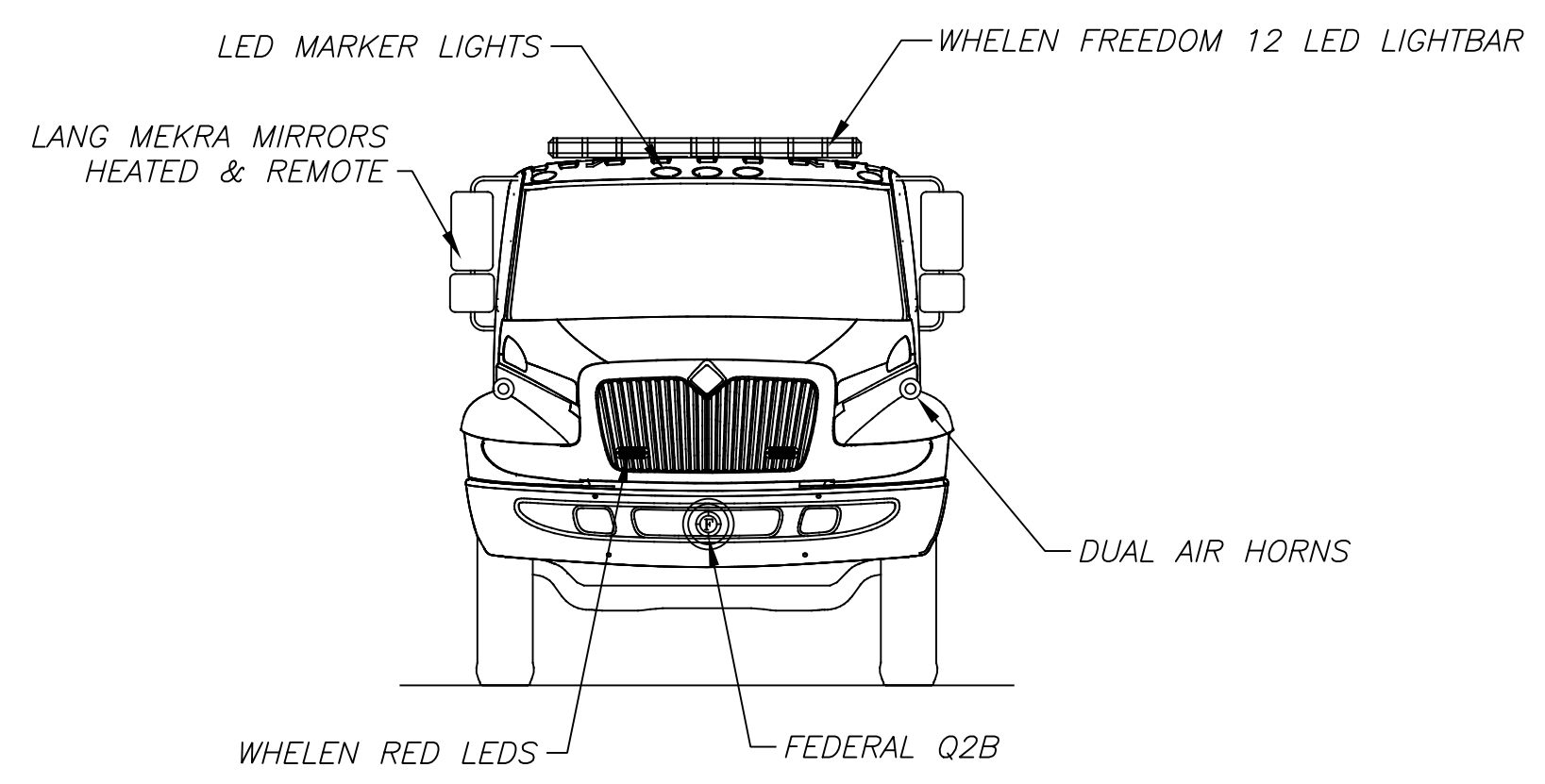
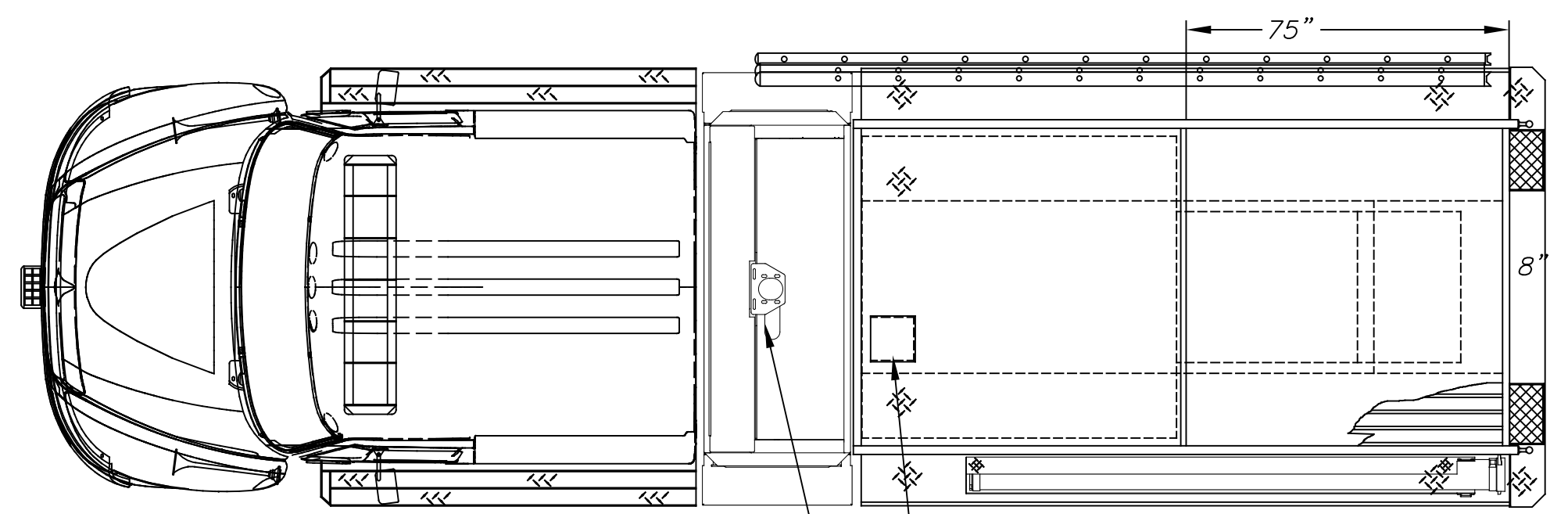

THE INFORMATION PRESENTED ON THIS DOCUMENT IS TO BE USED FOR ILLUSTRATIVE PURPOSES ONLY AND IT MAY NOT REFLECT, AESTHETICALLY OR OTHERWISE, PAST OR PRESENT MANUFACTURED PRODUCTS. SUTPHEN CORPORATION RESERVES THE RIGHT TO MAKE CHANGES IN THE DESIGN OF OUR PRODUCTS AT ANY TIME, WITHOUT NOTIFICATION.

The undersigned approves this data for construction in accordance with any changes as indicated on these drawings.

APPROVED BY: \_\_\_\_\_ DATE: \_\_\_\_\_  
(Authorized Fire Dept. Representative)

SALES REPRESENTATIVE: \_\_\_\_\_ DATE: \_\_\_\_\_

REV.	DESCRIPTION	BY	DATE
A	UPDATED DRAWING PER DESIGN CHANGES	JDH	02/21/19

THIS PRINT IS PROVIDED ON A RESTRICTED BASIS AND IS NOT TO BE USED IN ANY WAY DETRIMENTAL TO THE INTEREST OF SUTPHEN CORPORATION.

**SUTPHEN CORPORATION**  
FIRE APPARATUS SINCE 1890  
6450 EITERMAN ROAD  
DUBLIN, OH 43016

DR. J.HOWELL  
DATE 2.19.2019  
SCALE NONE

XXXXXXXXXX  
COMMERCIAL SERIES PUMPER  
C4 BODY STYLE  
1000 GALLON TANK

NO. REQ'D.  
DWG. NO.  
XXXXXXXXXX