

LEFT SIDE COMPARTMENTATION							
COMPT	DOORS	WIDTH	OPENING HEIGHT	INTERIOR HEIGHT	LOWER DEPTH	UPPER DEPTH	VOLUME (CU. FT.)
L1	DOUBLE	40.38"	61.5"	66.25"	26.06"	11.06"	29.7
L2	LIFT-UP	59.18"	31.75"	36.5"	N/A	11.06"	13.8
L3	DOUBLE	40.38"	61.5"	66.25"	26.06"	11.06"	29.7

RIGHT SIDE COMPARTMENTATION							
COMPT	DOORS	WIDTH	OPENING HEIGHT	INTERIOR HEIGHT	LOWER DEPTH	UPPER DEPTH	VOLUME (CU. FT.)
R1	DOUBLE	40.38"	31.38"	29.93"	26.06"	N/A	18.2
R2	DOUBLE	40.38"	31.38"	29.93"	26.06"	N/A	18.2

REAR STEP COMPARTMENT							
COMPT	DOORS	WIDTH	OPENING HEIGHT	INTERIOR HEIGHT	LOWER DEPTH	UPPER DEPTH	VOLUME (CU. FT.)
A1	ROLL-UP	39.62"	35"	43.38"	31.00"	N/A	30.8

TOTAL STORAGE: 140.4 CU. FT.

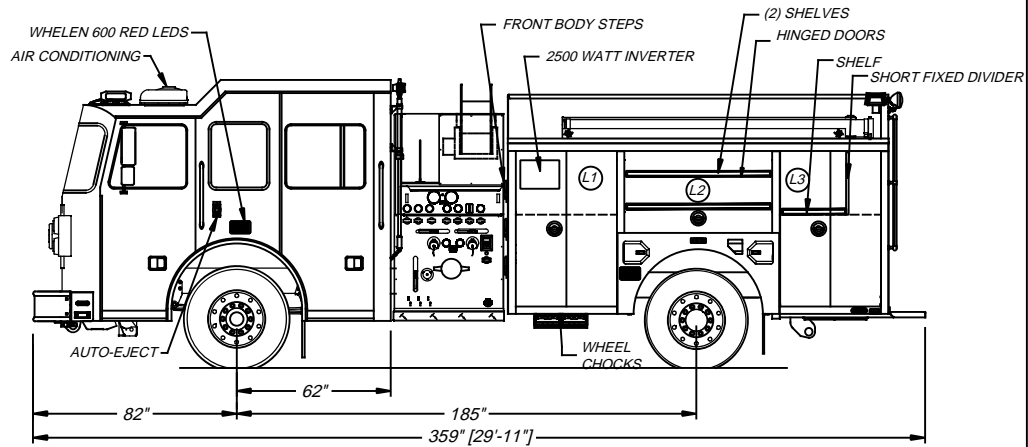
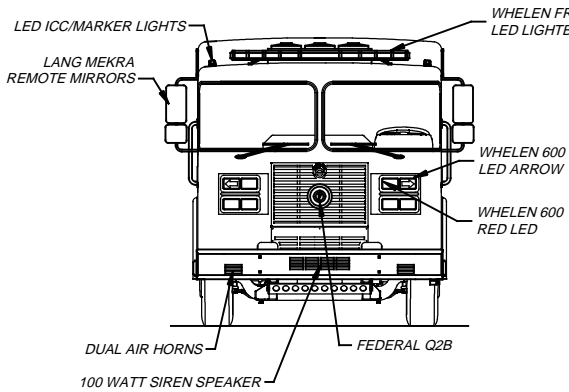
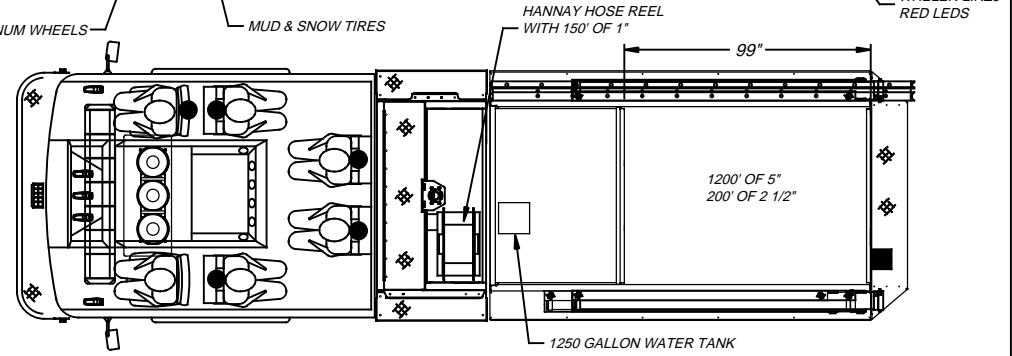

DIMENSIONS SHOWN ON THIS DRAWING ARE APPROXIMATE AND ARE SUBJECT TO MINOR DEVIATIONS DURING CONSTRUCTION.	CUSTOMER APPROVAL				DRAWN BY: J.HAULMAN	DATE: 5/16/2016	MFG. FACILITY: SPRINGFIELD	 MABSCOTT VOLUNTEER FIRE DEPARTMENT MABSCOTT, WV. PROGRAM 1 CUSTOM PUMPER
	IN THE EVENT OF A DISCREPANCY BETWEEN THE SUTPHEN SPECIFICATIONS AND DRAWING, THE SUTPHEN SPECIFICATIONS SHALL PREVAIL.	NAME: _____	TITLE: _____	DATE: _____				
DRAWING IS FOR REFERENCE ONLY. SOME ITEMS PROPOSED MAY NOT BE SHOWN OR NOTED.					THIS PRINT IS PROVIDED ON A RESTRICTED BASIS AND IS NOT TO BE USED IN ANY WAY DETRIMENTAL TO THE INTEREST OF SUTPHEN CORPORATION.		WBS. NO.: _____ HS-XXXX	