

| LEFT SIDE COMPARTMENTATION | | | | |
|-----------------------------|---------|--------------------|-----------------------------------|------------|
| COMPT | DOORS | OPENING DIMENSIONS | INSIDE DIMENSIONS | VOLUME |
| L1 | ROLL-UP | 50" w X 62 7/8" h | 56" w X 72" h X 27 1/4" d | 60 CU. FT. |
| L2 | ROLL-UP | 57" w X 33 5/8" h | 61 1/2" w X 42 1/2" h X 27 1/4" d | 36 CU. FT. |
| L3 | ROLL-UP | 50" w X 62 7/8" h | 53 1/2" w X 72" h X 27 1/4" d | 60 CU. FT. |
| H1 | LIFT-UP | | 175" L X 29" w X 24" h | 70 CU. FT. |
| RIGHT SIDE COMPARTMENTATION | | | | |
| COMPT | DOORS | OPENING DIMENSIONS | INSIDE DIMENSIONS | VOLUME |
| R1 | ROLL-UP | 50" w X 62 7/8" h | 56" w X 72" h X 27 1/4" d | 60 CU. FT. |
| R2 | ROLL-UP | 57" w X 33 5/8" h | 61 1/2" w X 42 1/2" h X 27 1/4" d | 36 CU. FT. |
| R3 | ROLL-UP | 50" w X 62 7/8" h | 53 1/2" w X 72" h X 27 1/4" d | 60 CU. FT. |
| H2 | LIFT-UP | | 175" L X 10 1/2" w X 12" h | 13 CU. FT. |
| REAR STEP COMPARTMENT | | | | |
| COMPT | DOORS | OPENING DIMENSIONS | INSIDE DIMENSIONS | VOLUME |
| A1 | ROLL-UP | 37 1/2" w X 46" h | 40" w X 53" h X 45" d | 49 CU. FT. |

TOTAL: 444 CU.FT.

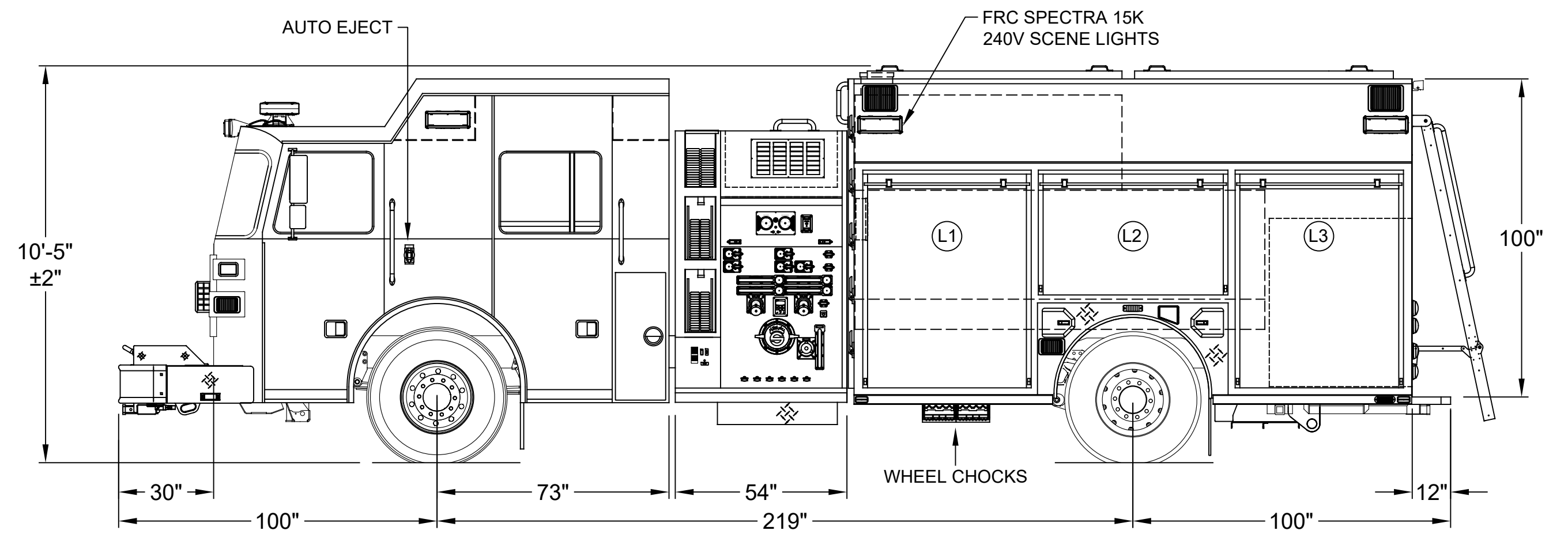
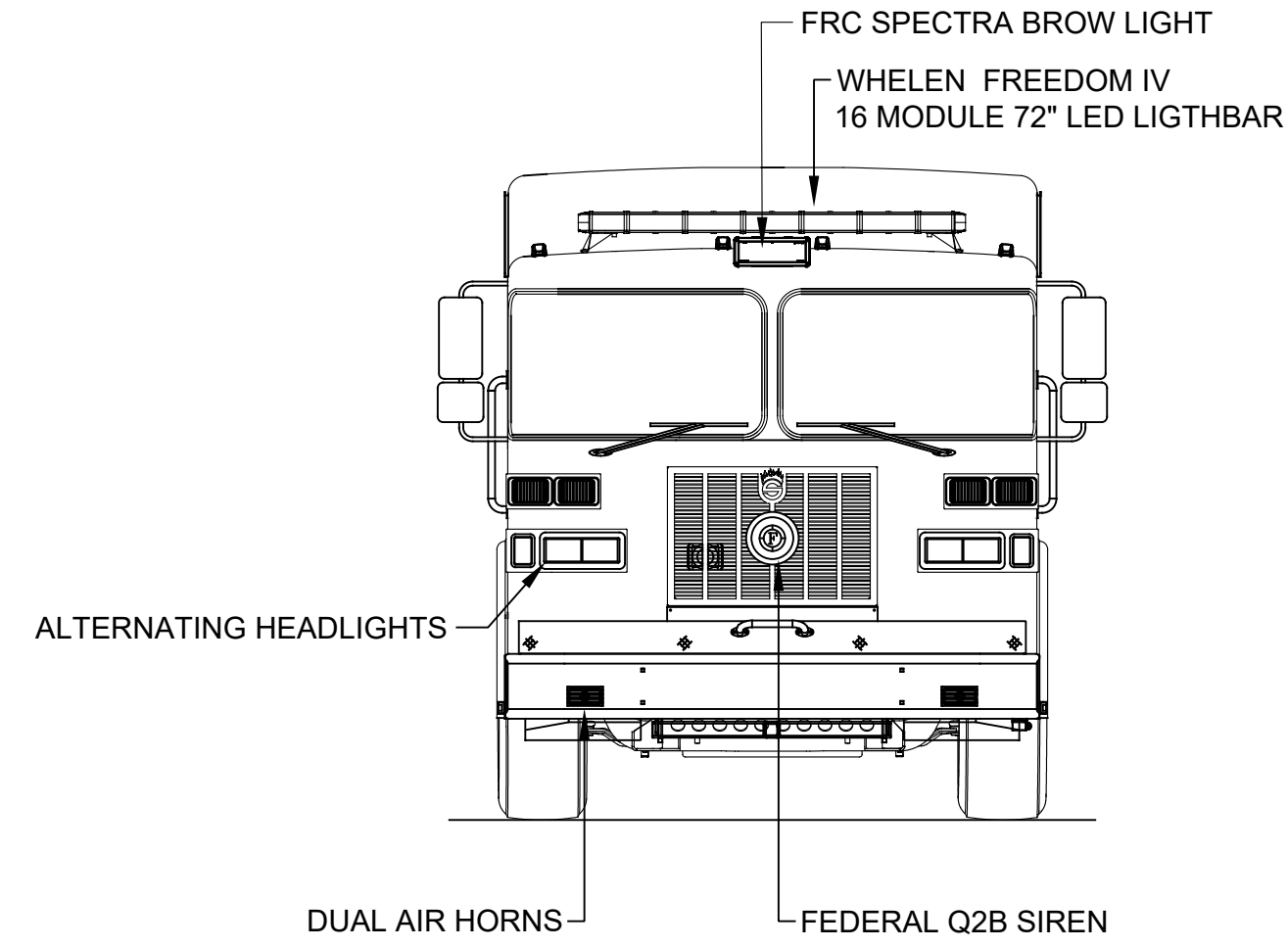
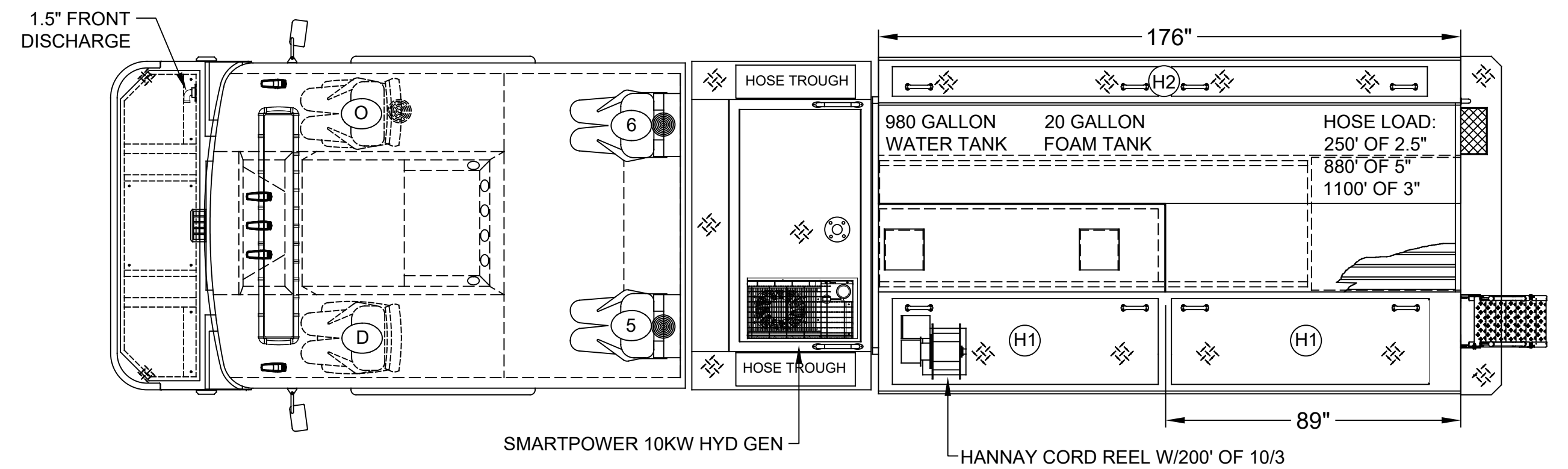

DIMENSIONS SHOWN ON THIS DRAWING ARE APPROXIMATE AND ARE SUBJECT TO MINOR DEVIATIONS DURING CONSTRUCTION.
IN THE EVENT OF A DISCREPANCY BETWEEN THE SUTPHEN SPECIFICATIONS AND DRAWING, THE SUTPHEN SPECIFICATIONS SHALL PREVAIL.
DRAWING IS FOR REFERENCE ONLY. SOME ITEMS PROPOSED MAY NOT BE SHOWN OR NOTED.

CUSTOMER APPROVAL

NAME: _____
TITLE: _____
DATE: _____

| REV. | DESCRIPTION | BY | DATE |
|------|--------------------------------------|-----|----------|
| B | UPDATED DRAWING PER CUSTOMER CHANGES | JDH | 09/20/18 |
| A | UPDATED DRAWING PER CUSTOMER CHANGES | JDH | 08/27/18 |

THIS PRINT IS PROVIDED ON A RESTRICTED BASIS AND IS NOT TO BE USED IN ANY WAY DETRIMENTAL TO THE INTEREST OF SUTPHEN CORPORATION.

DRAWN BY:
J.HOWELL
DATE:
08/24/18
MFG. FACILITY:
DUBLIN

SUTPHEN
JACKSON TOWNSHIP FIRE DEPARTMENT
GROVE CITY, OH
CUSTOM PUMPER - PA-16 BODY
DWG. NO.: JACKSON TWP, OH (2018 PA16).DWG